

2004 Battery Cross Reference Guide

HOW TO USE THIS APPLICATION GUIDE

This guide is intended to help select the proper battery or an alternate recommendation. The application section lists the **minimum** cold cranking amps @ 0°F and the recommended and optional replacement battery part numbers. The manufacturers are listed alphabetically. For Passenger Cars, Light Trucks and Vans, the applications are listed by year and engine size. The remaining vehicles and equipment are listed by model and/or engine numbers. To assure the proper replacement battery:

1. Find the correct manufacturer.
2. Determine the year and/or model.
3. Select the correct model or engine.
4. Read across to the part number and, if applicable, an optional part number.
5. Pay close attention to any footnoted information.

If you are specifying a battery to a customer who drives in extreme weather conditions and/or has a vehicle with many electrical options, **suggest a battery with more cold cranking amps than the minimum that is listed.** Batteries with more cold cranking amps will not harm the vehicle or equipment; however, batteries with fewer cold cranking amps may fail prematurely.

ABBREVIATIONS USED IN THIS GUIDE

AC	Air Conditioning	elec.	electric	No.	Number
A-C	Allis Chalmers	eng.	engine	O.E.	Original Equipment
Alt.	Altitude	ex.	except	OHC	Over Head Cam
AT	Automatic Transmission	Fed.	Federal	OHV	Over Head Valve
BCI	Battery Council International	Fig.	Figure	opt.	optional
Calif.	California	FI	Fuel Injection	pkg.	package
carb.	carburetor	Fla.	Florida	PS	Power Steering
CAT.	Caterpillar	FWD	Front Wheel Drive	PTO	Power Take Off
cc	cubic centimeter	GM	General Motors	RWD	Rear Wheel Drive
CCA	Cold Cranking Amps (0°F)	GSE	Gas Starting Engine	SAE	Post-type terminal
CFI	Central Fire Injection	HBL	Heated Back Light (rear window defrost)	S/C	Supercharged
comp.	compression	H.D.	Heavy Duty	SEO	Special Electrical Option
Cont.	Continental	H.O.	High Output	SGB	Sound-Guard Body
Conv.	Convertible	HP	Horsepower	SHO	Special High Output Engine
cyl.	cylinder	HSC	High Swirl Combustion	SOHC	Single Over Head Cam
DD	Detroit Diesel	IHC	International Harvester Co.	TBI	Throttle Body Injection
DES	Direct Electric Start	ind.	industrial	V	Venturi
DIN	Deutsche Industrie Normen	JD	John Deere	w/	with
DOHC	Dual Over Head Cam	L	Liter	w/o	without
EFI	Electronic Fuel Injection	LPG	Liquified Petroleum Gas	Wisc.	Wisconsin
ETR	Electronic Tuning Radio	MFI	Multi-Port Fuel Injection	2WD	2 Wheel Drive
		MT	Manual Transmission	4WD	4 Wheel Drive

BEST FIT ESTIMATE

Some equipment manufacturers do not provide complete replacement battery information. In some cases replacement battery size must be estimated using the best information available to guide the battery replacement data guide user. However, **the user is cautioned that the size stated is only an estimate.** Size and terminal post arrangements may vary from the original equipment manufacturer. Therefore, the user should obtain specific battery replacement size information from the owner's manual or from the dealer or equipment manufacturer. **Caution should always be exercised to assure proper cable hook-up and sufficient post clearance before closing the hood or battery cover.** Otherwise electrical system damage and/or **personal injury** could result.

BATTERY RATINGS

COLD CRANKING AMPS @ 0°F

The primary function of the battery is to provide power to crank the engine during starting. This process requires a large discharge of amperes over a short period of time. Therefore, the cold cranking performance rating is defined as **the discharge load in amperes which a new, fully charged battery at 0°F can deliver for 30 seconds and maintain a minimum voltage of 7.2 volts for a 12-volt battery, 3.6 volts for a 6-volt battery.** The cold cranking performance ratings listed in the application section of the guide are the **minimum** recommendation for each application. There is no warranty level or battery life expectancy expressed or implied by these ratings.

CRANKING AMPS @ 32°F

The cranking performance rating is defined as the discharge load in amperes which a new, fully charged battery **at a temperature of 32°F** can deliver for 30 seconds and maintain a minimum voltage of 7.2 volts for a 12-volt battery or 3.6 volts for a 6-volt battery.

RESERVE CAPACITY

Another function of the battery is to provide emergency power for ignition, lights, etc., in the event of failure of the vehicle's battery recharging system. The reserve capacity rating is defined as **the number of minutes a new, fully charged battery at 80°F can be discharged at 25 amperes** and maintain a minimum voltage of 10.5 volts for a 12-volt battery or 5.25 volts for a 6-volt battery.

HEAT SHIELDS

Protective heat shields are being used around batteries with increasing frequency to protect them from premature failure due to high underhood temperatures. **Failure to replace the heat shield after installation of a replacement battery may reduce its electrical performance and life.**

CAT® BATTERY CARE & MAINTENANCE GUIDE

IMPORTANT: ALWAYS WEAR EYE PROTECTION!



SAFETY PRECAUTIONS

Always wear safety glasses and a face shield when working on or near batteries.



PROPER INSTALLATION

Follow safety precautions — wear proper eye protection.

1. Before removing old battery, mark the positive (+) and negative (-) cables for proper connection to the new battery.
2. Always disconnect the ground cable first [usually negative (-)] to avoid any sparking around battery. Then disconnect the positive (+) cable and carefully remove the old battery.
3. Clean and inspect the battery tray. If necessary, replace the tray, hold-down and/or battery cables. Cable ends must be clean and corrosion free.
4. Put corrosion protection washers on battery terminals and then install new battery in same position as old one and tighten hold-down. Be sure terminals will clear hood, fender, box lid, etc.
5. Connect positive (+) cable first, then connect ground cable last. Use a special side terminal torque tool to tighten side terminal cables without damage. Never overtighten or hammer cables onto terminals.
6. Coat terminals and cable connection with a corrosion protection spray.

DO NOT OPEN

LEAD RECYCLE RETURN

DO NOT TIP

⚠ DANGER/POISON

SHIELD EYES. EXPLOSIVE GASES. CAN CAUSE BLINDNESS OR INJURY.

NO SPARKS, FLAMES OR SMOKING.

SULFURIC ACID CAN CAUSE BLINDNESS OR SEVERE BURNS.

FLUSH EYES IMMEDIATELY WITH WATER. GET MEDICAL HELP FAST.

KEEP OUT OF REACH OF CHILDREN - CONTAINS SULFURIC ACID. FOR MEDICAL EMERGENCY IN USA OR CANADA CONTACT: 800-458-5924. OTHER COUNTRIES CONTACT: 303-893-1322

PROPOSITION 65 WARNING: Battery posts, terminals and related accessories contain lead and lead compounds, chemicals known to the state of California to cause cancer and reproductive harm. **Wash hands after handling.**

All batteries generate explosive hydrogen gas. Keep sparks, flames and cigarettes away from batteries at all times. Do not connect or disconnect “live” circuits. To avoid creating sparks, always turn charging and testing equipment off before attaching or removing clamps. Always disconnect grounded cable first and connect it last to prevent dangerous sparks.

Perform all work in a well-ventilated area. Never lean directly over a battery while boosting, testing or charging it. **Protect your eyes!**

Batteries contain corrosive sulfuric acid that can destroy clothing and burn the skin. Neutralize acid spills with a paste made of baking soda and water. Be careful!



IN-MACHINE/VEHICLE SERVICE

Follow safety precautions — wear proper eye protection.

Prior to any testing, visually inspect the battery. Look for:

- Cracked or broken case or cover
- Leaking case-to-cover seal
- Loose cable connections
- Damaged or leaking terminals
- Corrosion

Neutralize any corrosion with a baking soda/water paste or battery cleaner spray. Scrape or brush off the residue and wash the area with clean water. Following your visual inspection, check the battery’s state of charge with a voltmeter.

NOTE: The Cat Digital Battery Analyzer (Part # 177-2330) enables you to determine whether a battery is bad or in need of a recharge in just 20 seconds, without having to remove the battery from the machine or vehicle. It quickly and accurately tests condition of 12-volt and 6-volt batteries, even discharged to as low as one volt.

Protect your eyes!

CAT® BATTERY CARE & MAINTENANCE GUIDE

IMPORTANT: ALWAYS WEAR EYE PROTECTION!



LOAD TESTING

Follow safety precautions — wear proper eye protection.

First perform an open circuit voltage test using the Caterpillar Digital Voltmeter, 4C6600, for a fast, accurate test. Then perform an adjustable load test. A load test is the best way to determine if the battery is delivering adequate electrical performance. Make sure your variable load tester is working properly.

Early Diagnosis!

Your Cat dealer can determine your battery's pre-charge condition with the Cat Digital Battery Analyzer (177-2330). This analyzer provides you with a quick and accurate procedure to know the condition of your battery before you spend time charging it up; or before replacing it with another battery. This analyzer quickly tests 6- or 12-volt batteries and tells you in 20 seconds if your battery is bad or in need of recharge. It can be used to test the full line of Caterpillar Batteries and any others that are within 50 to 2000 cold cranking amps, 65 to 2500 cranking amps, or 6 to 249 amp-hours capacity. The analyzer even works on batteries discharged down as far as one volt. In addition, a battery can even be tested without removing it from its vehicle.

If Discharged, Recharge!

1. You can't load test a discharged battery with most testers. Always attempt to charge it before load testing if below 12.4 volts. Refer to the charging chart for important information.

Turn Tester Off!

2. To avoid sparking, be sure load tester is off and battery is disconnected before hook-up. Use computer memory saver to retain the machine's electronic memory while the battery is disconnected.

Red to Positive & Black to Negative

3. Connect the positive (+) tester clamp to the positive (+) battery terminal. Then connect the negative (-) tester clamp to the (-) negative battery terminal. **Always protect your eyes.**

Set at 1/2 Cold Cranking Ampere rating

4. Set the tester for one-half the battery's 0°F cold crank rating and apply the load for 15 seconds. Battery ambient temperature must be 10°C (50°F) or greater.*

9.5 Volts OK for 12V battery! 4.7 Volts OK for 6V battery!

5. With the load still on the battery, check the tester reading. A steady reading of 9.5 volts for 12V battery or 4.7 volts for 6V battery while under load indicates a good battery.

Less than 9.5 Volts or 4.7 Volts Recharge or Replace

6. If the reading is below 9.5 or 4.7 volts under load, boost charge the battery and test it again. If the second reading is still below, replace the battery.

* (If the CCA rating is unknown, use 200 for auto batteries, 350 for commercial batteries and 100 for small-engine batteries.)
For complete load test procedure information refer to Caterpillar publication number SEHS9249.



ROTATE BATTERY STOCK

Use oldest batteries first.

Batteries require periodic stock rotation and routine charging. Always rotate stock using the FIFO (First In, First Out) method...Instead of FISH (First In, Still Here). Batteries packaged in cartons have the shipping date stamped on the carton. Keep the battery in the carton until it is put to use.

Batteries used in Caterpillar manufacturing facilities use the following shipping date codes:

Month		Year	
A – January	G – July	8 – 1998	4 – 2004
B – February	H – August	9 – 1999	5 – 2005
C – March	J – September	0 – 2000	6 – 2006
D – April	K – October	1 – 2001	7 – 2007
E – May	L – November	2 – 2002	
F – June	M – December	3 – 2003	

Always use oldest batteries first.

Example: A3 = Battery shipped January 2003.

Remember... wet or dry batteries, always rotate your stock!

CAT[®] BATTERY CARE & MAINTENANCE GUIDE

IMPORTANT: ALWAYS WEAR EYE PROTECTION!



JUMP STARTING

Shield eyes and face at all times...Never lean directly over battery when testing, jump starting or performing other maintenance.

Be sure any vent caps are tight and level, then place a damp rag over the vent caps of both batteries. Be sure machines do not touch each other.

1. Connect one end of positive (+) booster cable to positive (+) terminal of discharged battery, wired to starter or solenoid.
2. Connect other end of positive (+) booster cable to positive (+) terminal of assisting battery.
3. Connect one end of negative (-) booster cable to negative (-) terminal of assisting battery, wired to ground.
4. Complete hook-up by connecting other end of negative (-) booster cable **TO ENGINE BLOCK OF STALLED MACHINE—AS FAR AWAY FROM BATTERY AS POSSIBLE.**
5. Start both machines and remove cables in reverse order of connection. Discard the rag.



IMPORTANT: Both batteries or sets of batteries must be the same voltage! Do not mix voltages!

⚠ DANGER/POISON Causes Severe Burns

Contains sulfuric acid – Avoid contact with skin, eyes or clothing.

Antidote: External – Flush with water.

Internal – Drink large quantities of water or milk. Follow with milk of magnesia, beaten egg or vegetable oil.
Call physician immediately.

Eyes – Flush with water for 15 minutes and get prompt medical attention.

CALIFORNIA **Proposition 65** **Warning**

Battery posts, terminals and related accessories contain lead and lead compounds, and other chemicals known to the state of California to cause cancer and birth defects or other reproductive harm.
Wash hands after handling.



DRY CHARGE ACTIVATION

Important

Each vent opening is sealed with a removable plastic plug. Do not remove this plug until you are ready to fill the battery with electrolyte. Only when you are ready to fill, remove and discard the seal plugs. Use large vent caps to close openings when battery is filled and placed in service.

Activation

1. Fill each cell to proper level with battery-grade sulfuric acid of 1.265 specific gravity. Battery and acid must be at a temperature of 16°C to 38°C (60°F to 100°F) at time of filling.
2. Apply a load of 1/2 the Cold Cranking Ampere (CCA) rating for 10 seconds.

3. Note the voltage reading after 10 seconds. Use this chart to determine if the battery is ready for use or must be boost charged.

Size	Ready	Boost
12V	9V or more	below 9V
8V	6V or more	below 6V
6V	4.5V or more	below 4.5V

4. If a boost charge is required, the battery is to be charged for 20 minutes at the following rates:

15 amp for 12 Volt batteries under 600 CCA

40 amp for 12 Volt batteries 600-1200 CCA

**60 amp for all 8 Volt batteries and
12 Volt batteries over 1200 CCA**

40 amp for all 6 Volt batteries

5. After boost charging, the battery is to be load tested again, at 1/2 the CCA rating for 10 seconds. The battery may be put into service if 10 second voltages are as listed in step 3.
6. Recycle all scrap batteries. Your Cat Dealer accepts spent batteries for recycling.

CAT® BATTERY CARE & MAINTENANCE GUIDE

IMPORTANT: ALWAYS WEAR EYE PROTECTION!



BATTERY STORAGE TIPS

Storage temperature is critical for batteries. Batteries should be stored in a cool, dry area in an upright position. Keep them as cool as possible, but above freezing for maximum temperature life.

- Never stack batteries directly on top of each other unless they're in cartons, or on shipping pallets protected by corrugated packaging.
- Do not stack more than 2 high (3 high if automotive). Batteries must be in cartons or protected with corrugated packaging between layers.
- Test non-maintenance free wet batteries every 4-6 months, Maintenance Free every 12 months, and recharge if necessary.
- Dry batteries, that are not activated, have unlimited shelf life.

ALWAYS test and charge if necessary before installation.



CHARGING TIPS

Follow safety precautions — wear proper eye protection.

Batteries should be boost charged if the open circuit voltage (voltmeter) reading is below 12.4 volts. See chart below.

- Prior to charging, read the manufacturer's instructions for proper charger hook-up and use.
- Turn charger off and disconnect battery prior to hook-up to avoid dangerous sparks. Protect your eyes!
- A battery that has not begun to accept the minimum (1/2 of Recommended) charging current within 15 minutes at the highest charger setting (or voltage) should be replaced.
- If violent gassing or spewing of electrolyte occurs or the battery case feels hot to the touch, temporarily reduce or halt charging.
- Never attempt to charge a frozen battery. Allow it to warm up to room temperature before placing on charge.

BATTERY CHARGING RATE/TIME TABLES	
Amp Hour Rating	Charging Rate
15-34	5.0 Amps
35-49	7.5 Amps
50-69	10 Amps
70-99	15 Amps
100-129	20 Amps
130-164	25 Amps
165-199	30 Amps
200-249	35 Amps

OPEN CIRCUIT VOLTAGE			
12 Volt Battery	8 Volt Battery	6 Volt Battery	Charging Time
12.40 & above	8.27 & above	6.20 & above	Load Test No Charging Required
12.39 - 12.20	8.26 - 8.13	6.19 - 6.10	2.0 Hours
12.19 - 12.00	8.12 - 8.00	6.09 - 6.00	3.0 Hours
Below 12.00	Below 8.00	Below 6.00	4.0 Hours

Important: Never overcharge batteries! Excessive charging will shorten battery life. For complete battery charging and test procedures refer to Cat Special Instruction, SEHS7633.

Proper Charging of Threaded Post Terminal Batteries

Group 31 Charging Posts should be used to ensure the testing and charging results for threaded stud terminal batteries. Due to their 3/8" thread stud, the charging posts will provide a flush lead-to-lead contact. Tighten the charging post until it is snug and secure.

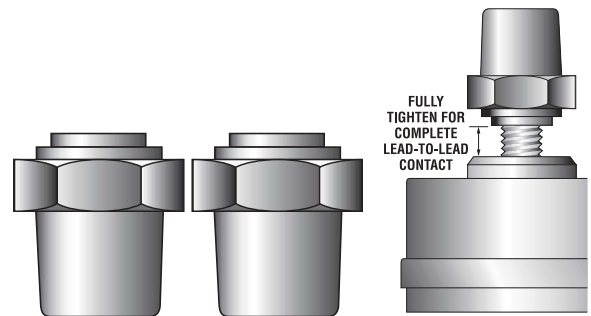

Group 31 Charging Posts

DO NOT USE Stainless Steel Nuts or the Threaded Stud for testing or charging batteries. They do not provide the necessary lead-to-lead contact and can reduce your Cold Cranking Amperage (CCA) and state of charge readings.

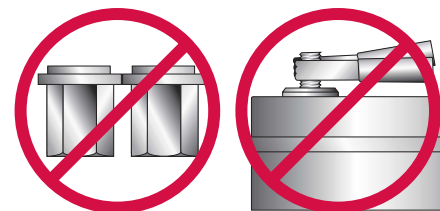

Battery Nuts

Threaded Stud

IMPORTANT: NEVER overcharge batteries! Excessive charging WILL shorten battery life. For complete battery charging and test procedures refer to the Battery Test Procedure SEHS7633.

CAT® BATTERY CARE & MAINTENANCE GUIDE

IMPORTANT: ALWAYS WEAR EYE PROTECTION!



CHOOSE PLENTY OF POWER

*Choose cranking amps...
Not months of warranty!*

Always use a battery that has enough cranking power, reserve capacity and vibration resistance to get the job done. Consider the machine or vehicle manufacturer's recommended capacity to be a minimum-capacity guideline. A machine or vehicle that has a lot of electrical accessories such as on-board computers, air conditioning, two way radios, etc. will need a more powerful battery for optimum performance.

Along with electrical accessories, temperature also has an effect on battery performance. Machines or vehicles that are operated in extremely cold climates may need a battery with a higher CCA rating.

Remember, you can't buy a battery with too much power!

Starting Power Available from Battery

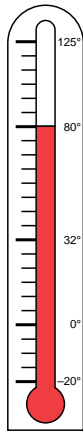
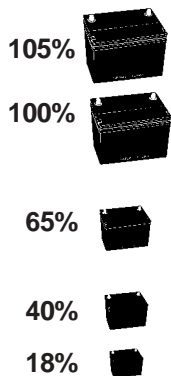

Starting Power Required By Engine

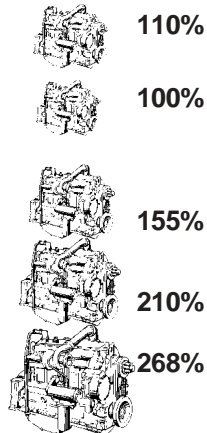

Temperature has a dramatic effect on a battery's ability to crank an engine. Not only does cold rob batteries of power, it also stiffens motor oil, making engines harder to start. And heat can damage batteries by causing internal components to wear out quickly while also making engines difficult to start.

DISCLAIMER: The battery replacement data published in this guide has been obtained from Battery Council International. The information contained in this guide was the most current information available at the time of publication. The information is subject to change upon notice from equipment manufacturers or field experience. Users should consult the most current edition of this application guide. The marketer and manufacturer expressly deny any responsibility for the accuracy provided. While every effort has been made to accurately catalog the replacement battery information in this guide, any liability for damages as a consequence of using the information in this guide is expressly denied. Users should also attempt to obtain replacement battery data from the original equipment manufacturer's user manual or service department for their specific application.